

## 3.3X4.8M CAR TENT

### DEAR CUSTOMER

*Assembly with more than one person suggested.*

*Please use gloves when assembling the metal frame portion of this unit.*

The metal components of this product have been treated with a rust preventive coating that may feel oily to the touch. This coating is not dangerous, but may dirty your hands during assembly. We recommend that you wipe metal parts clean with a mixture of warm water and dish detergent prior to assembly. Should your hands become dirty, simply wash with soap and water.

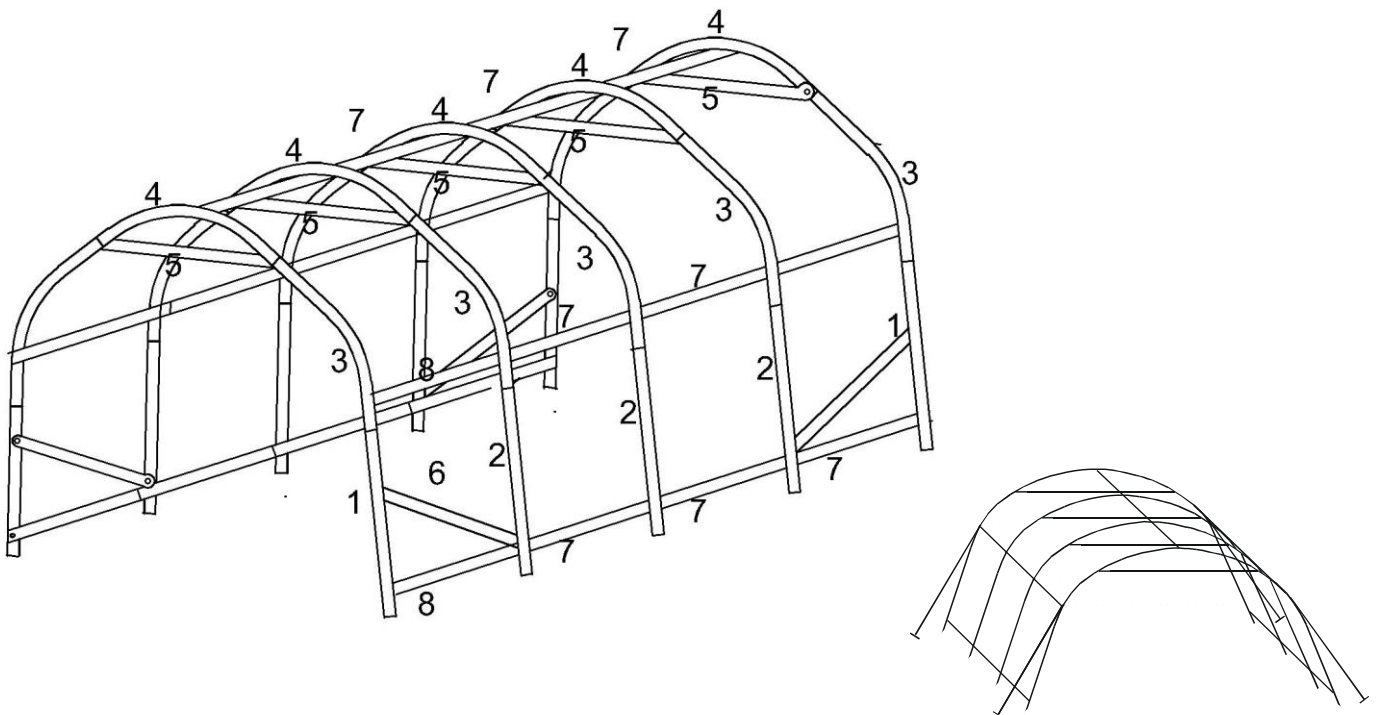

# ASSEMBLY INSTRUCTIONS

## 1. Assembly of middle arches(Wing nuts are always on inside of the shelter)

- Take one arch (4); assemble with one main corner arch (3) on the left side.
- Take the other corner arch (3) on the right side.
- Take one completed arch; put screw 1.75" through holes on the right side and attach bar (5) over screw and tighten wing nut
- Repeat same procedures on the left side.

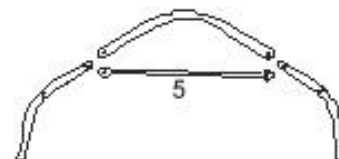

2. Repeat step 1 for the remaining middle arches.

## 3. Assembly of legs

- Insert (1) legs into an end arch one side at a time, pls pay attention to use screw to tight the leg to the corner arch.
- Insert (2) legs to the second arch.
- Add second arch to assembly connecting pipe (7) into (8) with screws 3" and diagonal bar (6) with screws 3" and with wing nuts. See sketch at front page. Note: (8) should be placed at last section.
- Repeat step b) and c) until the whole shelter is completed.

**e) Make sure the bottom of the tent standing on the ground with a square shape, this is very important.**

## 4. Cover installation (Ties are always on the inside)

- Place the roof in front of the shelter as illustrated.
- Unfold as illustrated then lift onto shelter as is.
- Place cover over the completed structure making sure that the roof is even on the two end side of the frame
- Insert the pipe No.9 into the bottom pocket, use strap to go through the cut point, tie Pipe No.9 together with Pipe No.8 and No.7. In this way, roof is tighten to the frame. Make left and right even. As the photos shows.
- In the ends of the shelter, there is two ropes inside, tighten the rope so the roof end will come down and close the frame, pls use strength and make it even, then tie the rope to the spiral peg. Like the picture shows.

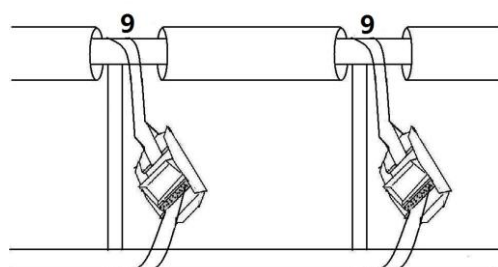
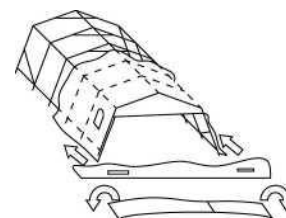

7 & 8

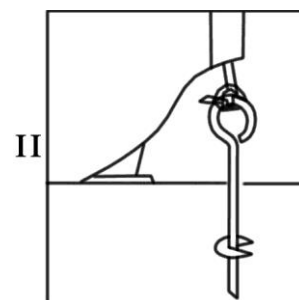

## 5. Door Assembly

Attached the door to the frame by bungee ball, each grommet use one bungee cord

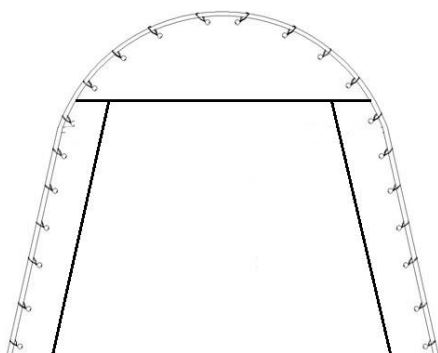

## 6. Anchoring garage.

Place your garage in the final position you want then close the doors, front and back if supplied before anchoring, anchor with brackets and peg as per diagram on the first page.



## 7. Foot of the shelter.

At last step, put the separate foot into the leg, use 1.75" screw to fix it. Then insert the 8x300mm PEG to stable the shelter into ground.

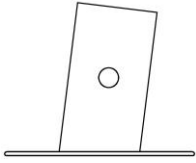

# PARTS LIST

PART NO.	DESCRIPTION		QTY
1	Back Leg		4
2	Regular Leg		6
3	Corner arch		10
4	Center Arch		5
5	Crossbar		5
6	Diagonal		4
7	Connection pipe		15
8	Connection pipe		5
9	Tighten pipe		8
	Peg		8
	Spiral peg		4
	Floor Bracket		4
	Elastic Bungee		32
	1.75 inch screw		20
	3 inch screw		29

Wing nut



49

Buckle

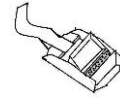

16

Foot



10

PEG(8X300)



10

Roof

1

**Door**

**2**